

COLOR CODE FOR WIRING CONNECTING TRAFFIC SIGNAL LAMPS

NOTE: No splices allowed between traffic signal head and controller.

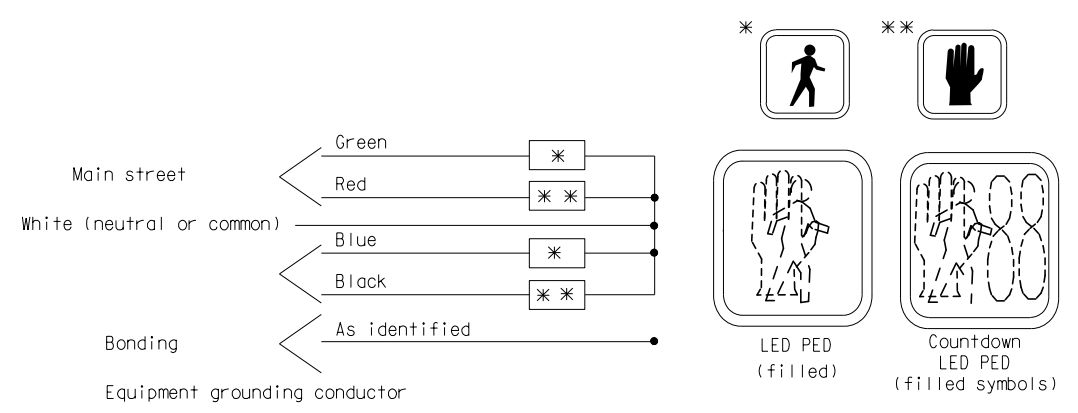

**COLOR CODE FOR WIRING CONNECTING PEDESTRIAN SIGNAL LAMPS
(WALKING PERSON - HAND SYMBOL)**

NOT TO SCALE

File: RefDoc/TR/Signals/Web/Sp Det/Fin/SIG230A.dgn Rev. 02/16/17

| | | | |
|---|--|--|------------------|
| <p>PREPARED BY TRAFFIC AND SAFETY</p> <p>DRAWN BY: DJF</p> <p>CHECKED BY:</p> | <p>ENGINEER OF DELIVERY</p> | <p>MICHIGAN DEPARTMENT OF TRANSPORTATION BUREAU OF HIGHWAYS DELIVERY STANDARD PLAN FOR COLOR CODE WIRING/ EQUIPMENT GROUNDING</p> | |
| | <p>ENGINEER OF DEVELOPMENT (SPECIAL DETAIL) FHWA APPROVAL DATE</p> | <p>PLAN DATE</p> | <p>SIG-230-A</p> |

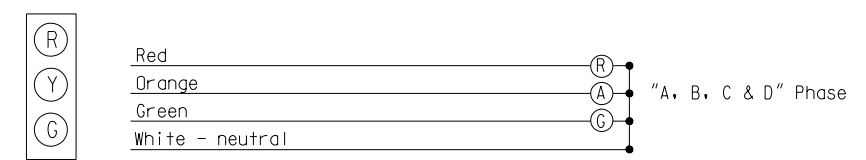

STANDARD - 3 COLOR SIGNAL DISPLAY

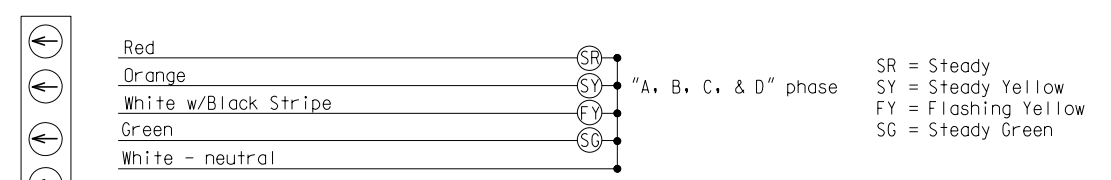

FLASHING YELLOW ARROW (FYA) - 4 COLOR SIGNAL DISPLAY

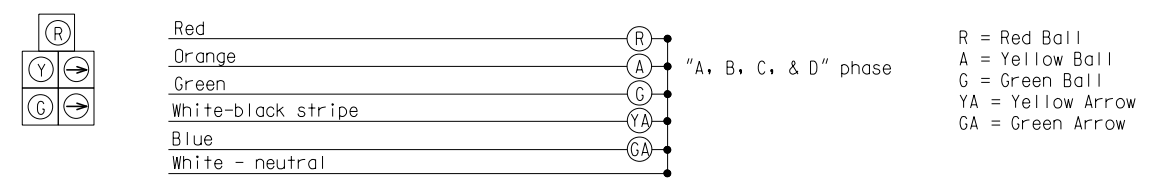

DOG HOUSE W/RIGHT TURNS - 5 COLOR SIGNAL DISPLAY

COLOR CODE FOR WIRING CONNECTING TRAFFIC SIGNAL LAMPS

NOT TO SCALE

File: RefDoc/TR/Signals/Web/Sp Det/Fin/SIG230A.dgn Rev. 02/16/17

| | | | | |
|--|--|------------------|------------------|-------------------------|
| <p>MICHIGAN DEPARTMENT OF TRANSPORTATION BUREAU OF HIGHWAYS DELIVERY STANDARD PLAN</p> | <p>(SPECIAL DETAIL) FHWA APPROVAL DATE</p> | <p>PLAN DATE</p> | <p>SIG-230-A</p> | <p>SHEET 2 of 6</p> |
|--|--|------------------|------------------|-------------------------|

| AS-LET PLAN REVISIONS | | | | | | | | | DATE: | CS: | DRAWING | SHEET |
|-----------------------|------|------|-------------|-----|------|------|-------------|-------|--------------|-----|---------|-------|
| NO. | DATE | AUTH | DESCRIPTION | NO. | DATE | AUTH | DESCRIPTION | | | | | |
| | | | | | | | | FILE: | DESIGN UNIT: | JN: | | |
| | | | | | | | | | TSC: | | | |

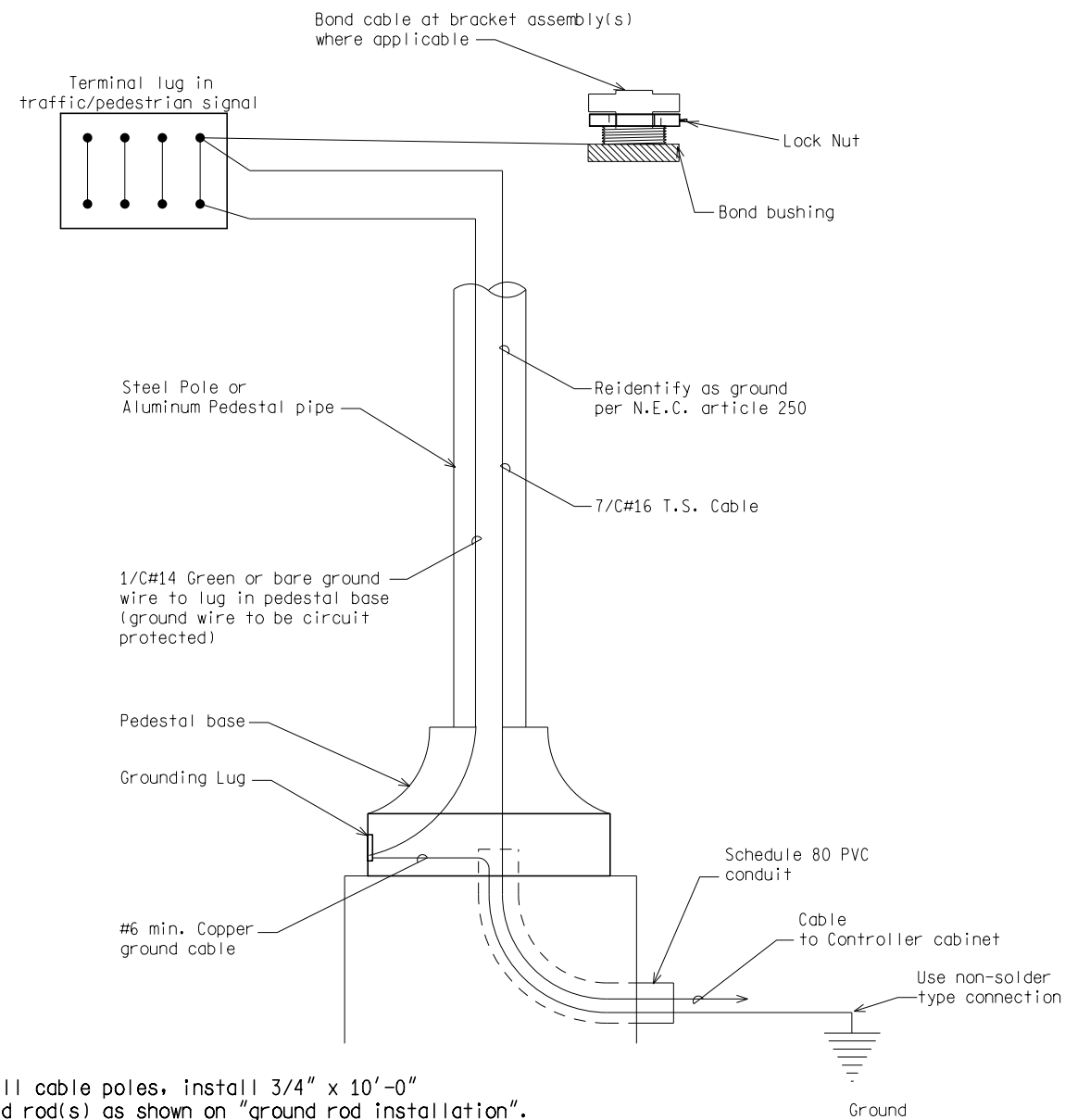

NOTE:
 For all cable poles, install 3/4" x 10'-0"
 ground rod(s) as shown on "ground rod installation".
 Connect ground rod(s) with #6 min. copper wire to
 messenger wire with non-solder type connection.

STEEL POLE/PEDESTAL GROUNDING DETAIL

NOT TO SCALE

| | | | | |
|--|--|-----------|-----------|-----------------|
| MICHIGAN DEPARTMENT OF TRANSPORTATION BUREAU OF HIGHWAYS DELIVERY STANDARD PLAN | (SPECIAL DETAIL) FHWA APPROVAL DATE | | SIG-230-A | SHEET 3 of 6 |
| File: RefDoc/TR/Signals/Web/Sp Det/Fin/SIG230A.dgn Rev. 02/16/17 | | PLAN DATE | | |

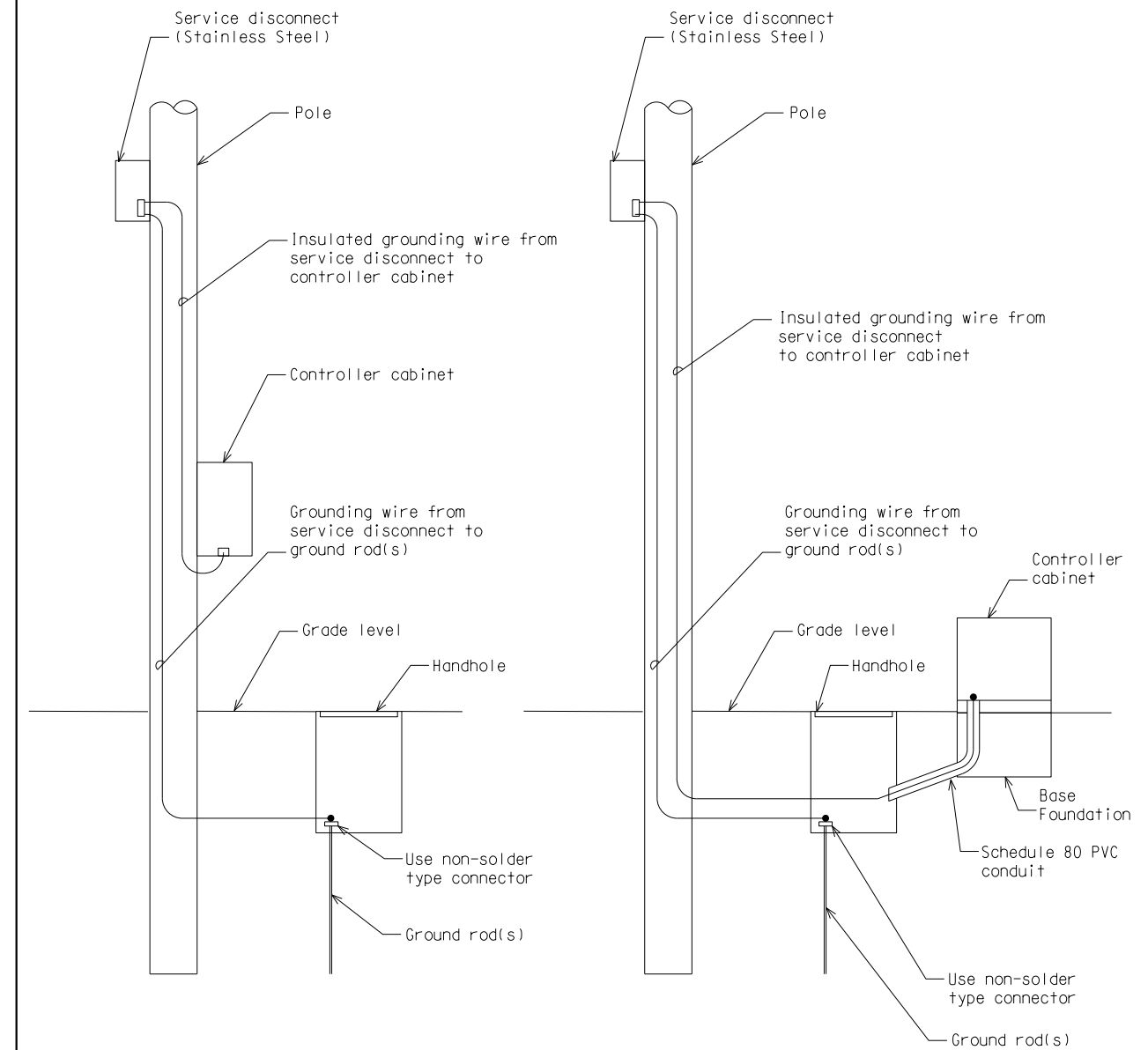

GROUNDING

Install 3/4" x 10'-0" copper clad ground rod(s)
 as required to provide less than 10 OHM resistance to
 ground.

Grounding wire #6 AWG min. bare copper grounding wire
 shall be installed to meet N.E.C. and utility
 company specs.

Ground wire from disconnect to ground rod to be in
 moulding (wood pole or post) or inside the pole
 (steel). Ground wire from disconnect to controller
 cabinet to be in conduit (wood pole, wood post, and
 steel pole).

CONTROLLER CABINET GROUNDING DETAIL

NOT TO SCALE

| | | | | |
|--|--|-----------|-----------|-----------------|
| MICHIGAN DEPARTMENT OF TRANSPORTATION BUREAU OF HIGHWAYS DELIVERY STANDARD PLAN | (SPECIAL DETAIL) FHWA APPROVAL DATE | | SIG-230-A | SHEET 4 of 6 |
| File: RefDoc/TR/Signals/Web/Sp Det/Fin/SIG230A.dgn Rev. 02/16/17 | | PLAN DATE | | |

| AS-LET PLAN REVISIONS | | | | | | | |
|-----------------------|------|------|-------------|-----|------|------|-------------|
| NO. | DATE | AUTH | DESCRIPTION | NO. | DATE | AUTH | DESCRIPTION |
| | | | | | | | |



| | | | |
|--------------|-----|---------|-------|
| DATE: | CS: | DRAWING | SHEET |
| DESIGN UNIT: | JN: | | |
| TSC: | | | |
| FILE: | | | |

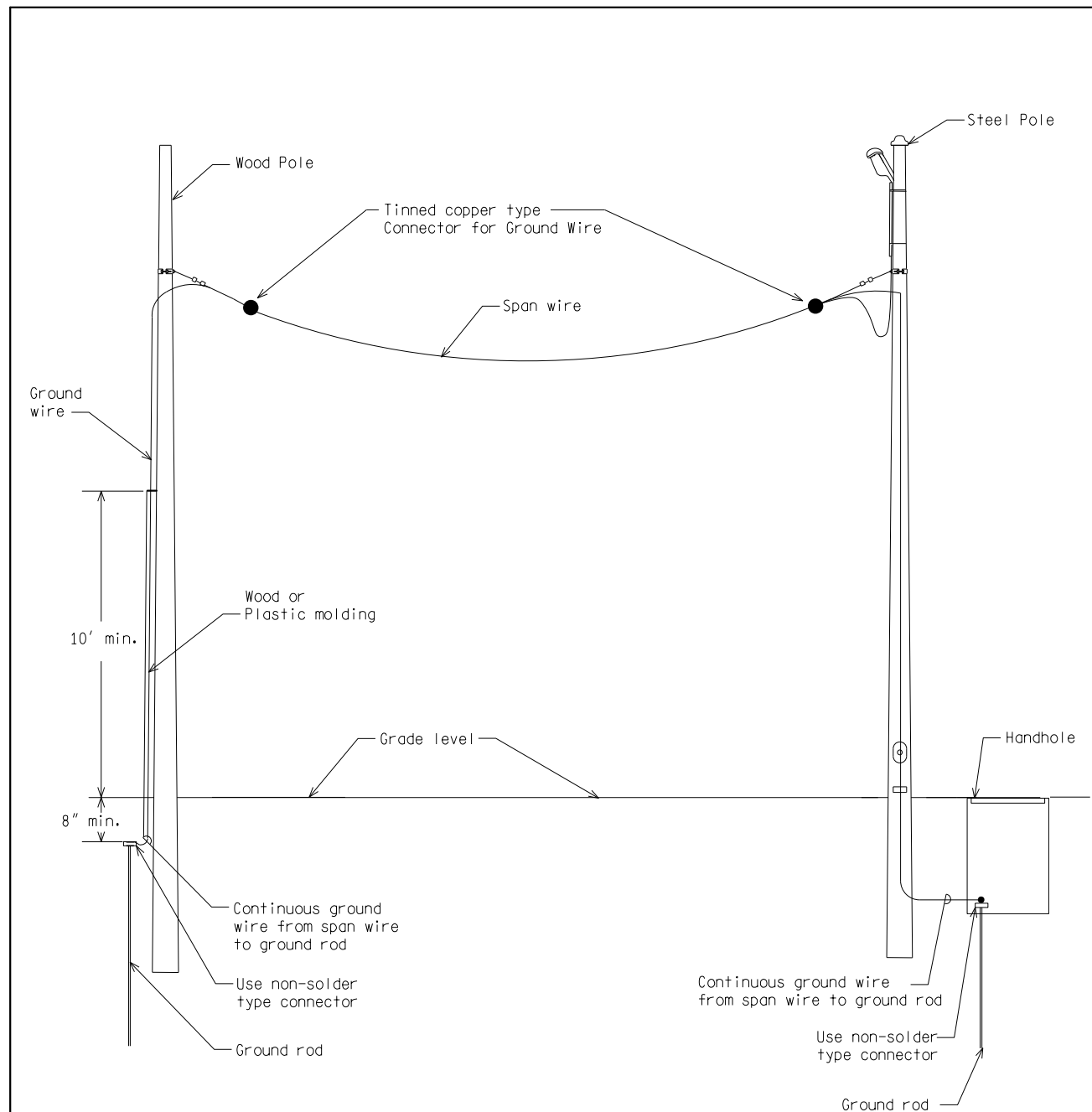

SPAN WIRE GROUNDING DETAIL

NOT TO SCALE

| | | | | |
|--|--|-----------|-----------|-----------------|
| MICHIGAN DEPARTMENT OF TRANSPORTATION BUREAU OF HIGHWAYS DELIVERY STANDARD PLAN | (SPECIAL DETAIL) FHWA APPROVAL DATE | PLAN DATE | SIG-230-A | SHEET 5 of 6 |
| File: RefDoc/TR/Signals/Web/Sp Det/Fin/SIG230A.dgn Rev. 02/16/17 | | | | |

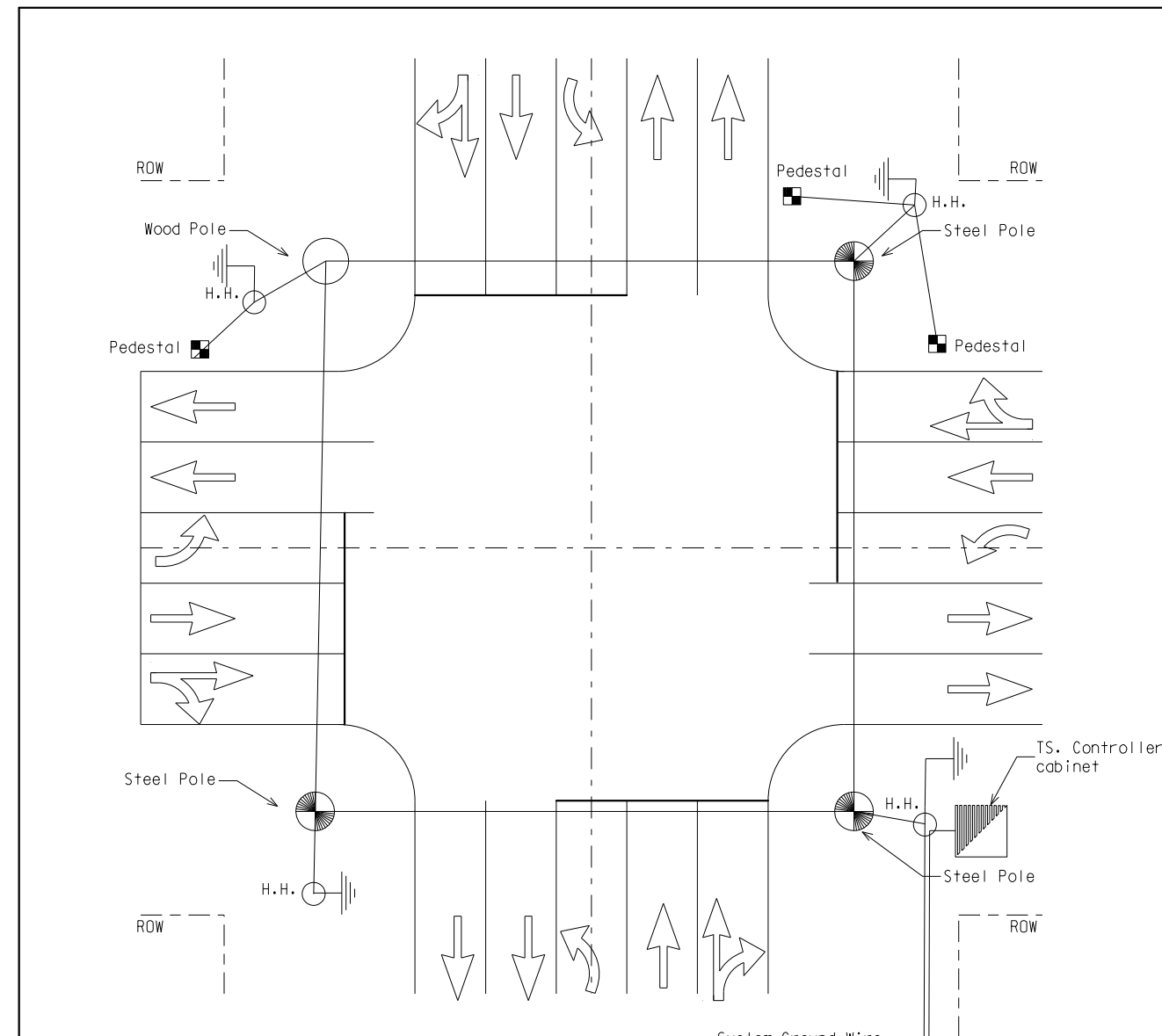

- 1) All ground rods shall be 3/4" x 10' in length copperclad.
- 2) Ground rods shall be drive straight down, so that only the required portions of of the ground rod is exposed to attach the ground wires.
- 3) All ground rods shall be connected to each other or to a span wire with a single #6 AWG copper conductor.
- 4) Each ground wire attaching to a ground rod shall have its own approved acorn type connector.
- 5) Do not install any ground rods within 10' of any other ground rods from other grounding.
- 6) The grounding system shall measure 10 ohms or less.
- 7) A separate insulated green #6 AWG copper ground is required from the service disconnect (safety switch) to the ground bussbar in the controller cabinet.
- 8) Ground rod for each steel pole, wood pole, pedestal and/or traffic signal controller cabinet shall be located in the adjacent handhole as indicated on the plans or as directed by the Engineer.
- 9) All metal bases must be connected to a ground rod with a #6 ground wire.

SYSTEM GROUNDING DETAIL

NOT TO SCALE

| | | | | |
|--|--|-----------|-----------|-----------------|
| MICHIGAN DEPARTMENT OF TRANSPORTATION BUREAU OF HIGHWAYS DELIVERY STANDARD PLAN | (SPECIAL DETAIL) FHWA APPROVAL DATE | PLAN DATE | SIG-230-A | SHEET 6 of 6 |
| File: RefDoc/TR/Signals/Web/Sp Det/Fin/SIG230A.dgn Rev. 02/16/17 | | | | |

| AS-LET PLAN REVISIONS | | | | | | | |
|-----------------------|------|------|-------------|-----|------|------|-------------|
| NO. | DATE | AUTH | DESCRIPTION | NO. | DATE | AUTH | DESCRIPTION |
| | | | | | | | |



| | | | |
|--------------|-----|---------|-------|
| DATE: | CS: | DRAWING | SHEET |
| DESIGN UNIT: | JN: | | |
| TSC: | | | |
| FILE: | | | |